

ITEM	QTY	DESCRIPTION	WIDTH	LENGTH	UM	PART NUMBER	MATERIAL	TYP
1	1	SHEET, RUBBER (POND LINER)	5.00	26.00	EA		RUBBER	C
2	2	1 X 4		10.0	EA		PINE	C
3	1	PADDLE	1.50	4.00	EA		RUBBER	C
4	1	PVC PIPE, 1/2"		4.00	EA		PVC	C

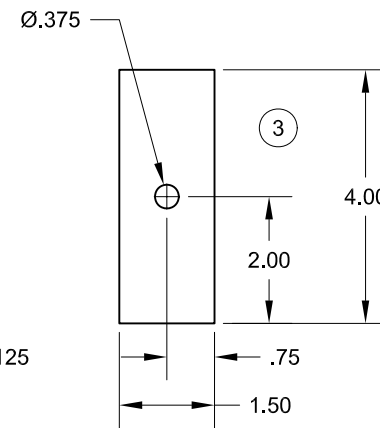
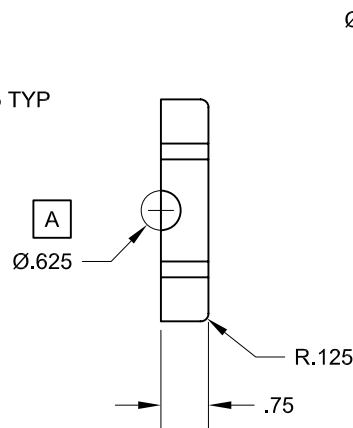
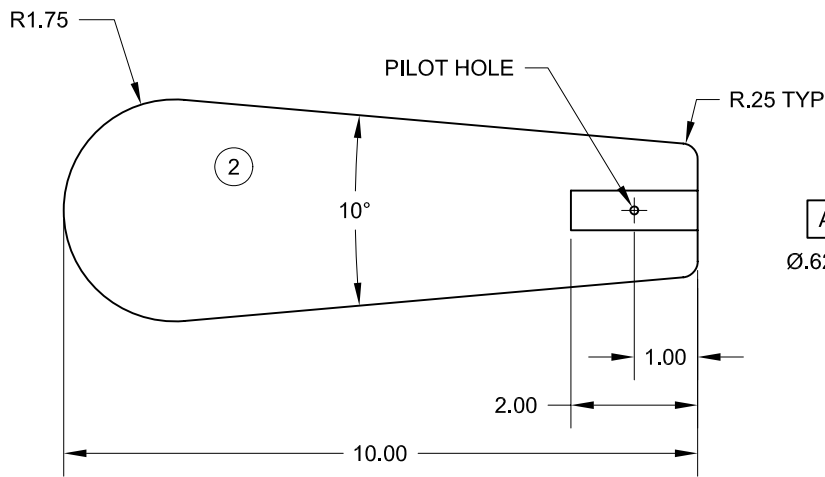
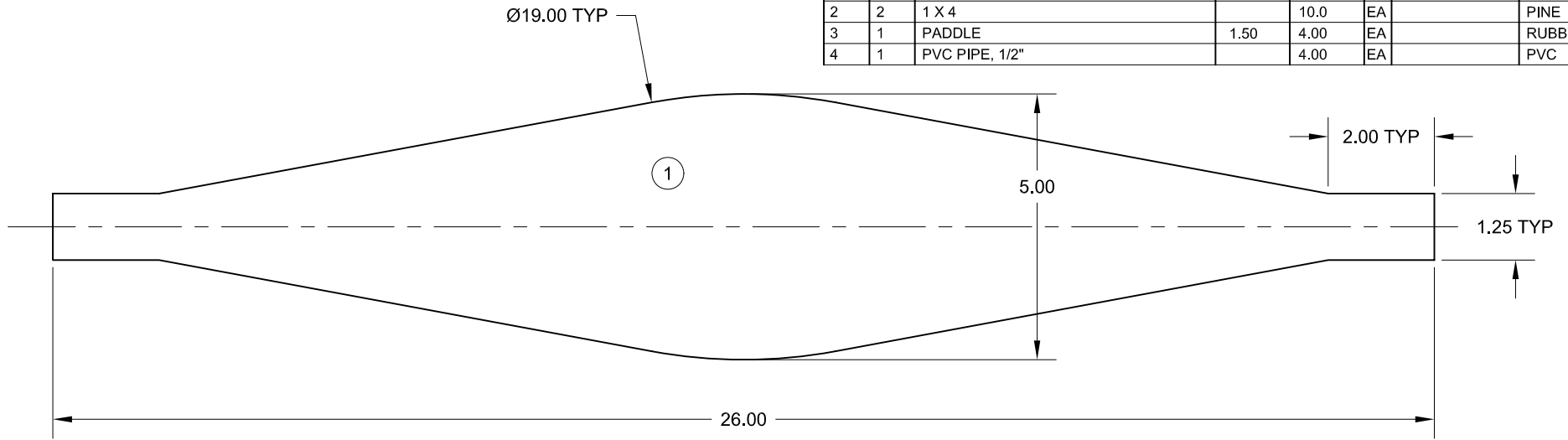

A CLAMP TOP AND BOTTOMS TOGETHER AND DRILL WITH SPADE DRILL.

THIS DRAWING IS THE PROPERTY THE CUSTOMER. IT SHALL NOT BE COPIED (IN WHOLE OR IN PART), FOR MANUFACTURE OR OTHERWISE DISCLOSED WITHOUT PRIOR WRITTEN CONSENT OF THE CUSTOMER.		TOLERANCES		SCALE: 1:1	TITLE: PACK 409 PROJECT BELLOWS (AIR MACHINE)	
		MACHINING	FABRICATION	DRAWN BY: MGATES	DATE: 06-OCT-08	REV
ESTIMATED WEIGHT:	FIRST ORDERED ON:	X. ±.040	ALL ±.06	CHECKED BY:	SIZE: A	SHEET 1 OF 1
		X.X ±.020	ANGULAR ±.2°	DATE:	DWG NO: BELLOWS COMPONENTS	
		X.XX ±.010	ALL FINISHES 125mu			
		X.XXX ±.005	DEBURR ALL SHARP CORNERS OR EDGES			
		ANGULAR ±.12'				