

ITEM	QTY	DESCRIPTION	WIDTH	LENGTH	UM	PART NUMBER	MATERIAL	TYP
1	1	EYELET PURCHASE FROM TANDY LEATHER			EA		STEEL	F
2	1	ARROWHEAD CUTOUT PURCHASE FROM WALMART			EA		ALUM	F
3	1	SUEDE LACING PURCHASE FROM WALMART		13.00	EA		LEATHER	F
4	8	BEAD, WOODEN PURCHASE FROM MICHAELS CRAFT			EA		WOOD	F
5	1	EYELET PURCHASE FROM TANDY LEATHER			EA		STEEL	F
6	1	LEATHER STRAP PURCHASE FROM CRAFT STORE AS 8-1/2" X 11" SHEET			EA	LEATHER		F
REF		ASSEMBLY INSTRUCTIONS			EA			D

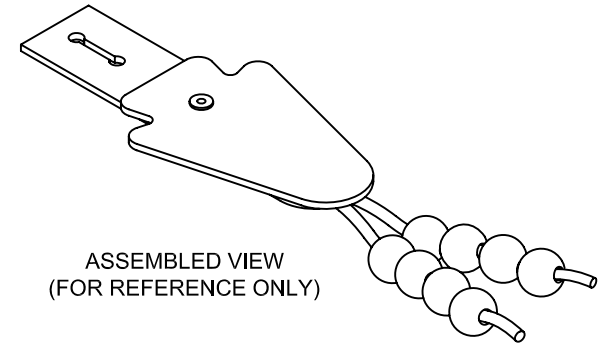
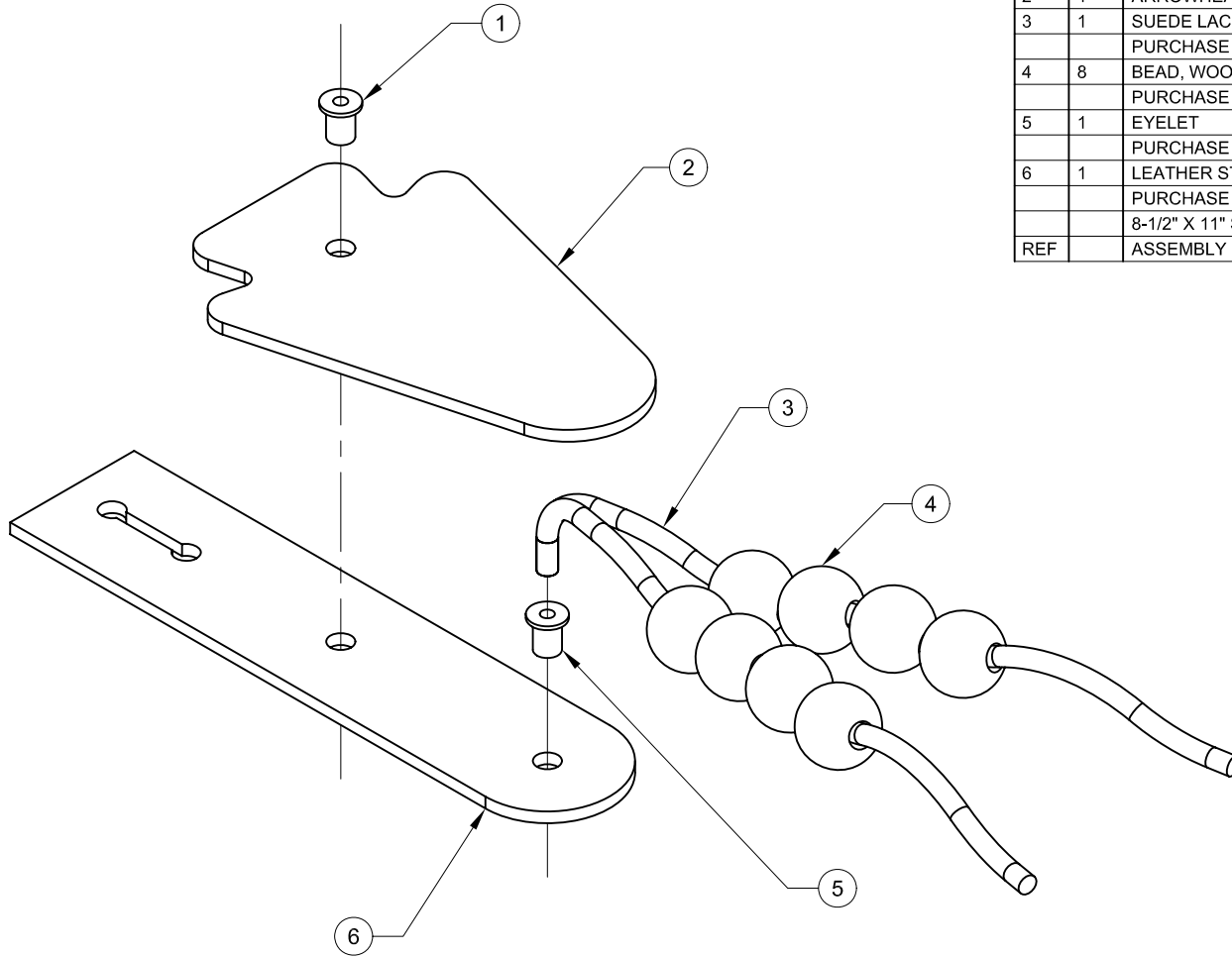

THIS DRAWING IS THE PROPERTY THE CUSTOMER. IT SHALL NOT BE COPIED (IN WHOLE OR IN PART), FOR MANUFACTURE OR OTHERWISE DISCLOSED WITHOUT PRIOR WRITTEN CONSENT OF THE CUSTOMER.		TOLERANCES		SCALE: 1:1	TITLE: PACK 409 - PROJECT	
		MACHINING	FABRICATION	DRAWN BY: MGATES	PROGRESS TOWARDS RANKS	
ESTIMATED WEIGHT:	FIRST ORDERED ON:	X	±.040	ALL	±.06	DATE: 22SEPT08
		X,X	±.020	ANGULAR	2'	
		X,XX	±.010	ALL FINISHES	125mu	SIZE: A SHEET 1 OF 1
		X,XXX	±.005	DEBURR ALL SHARP	CORNERS OR EDGES	REV
		ANGULAR	± 1/2"	DATE:		DWG NO: ASSEMBLY