

ITEM	QTY	DESCRIPTION	WIDTH	LENGTH	UM	PART NUMBER	MATERIAL	TYP
1	4	CAP SCREW, HEX HEAD 3/8"-16		3.0	EA		STEEL	P
2	1	PLATE, UPPER DIE			EA		STEEL	D
3	4	SPRING, COMP. 1/2" O.D. .047 WIRE PURCHASE FROM McMASTER-CARR		2.0	EA	9657K121	STEEL	P
4	4	CAP SCREW, IND HEX 1/4"-20		1.25	EA		STEEL	P
5	2	STOP			EA		ALUM	D
6	1	DIE, UPPER			EA		STEEL	D
7	1	DIE, LOWER			EA		STEEL	D
8	1	PLATE, LOWER DIE			EA		STEEL	D
9	4	CAP SCREW, IND HEX. 1/4"-20		.50	EA		STEEL	P

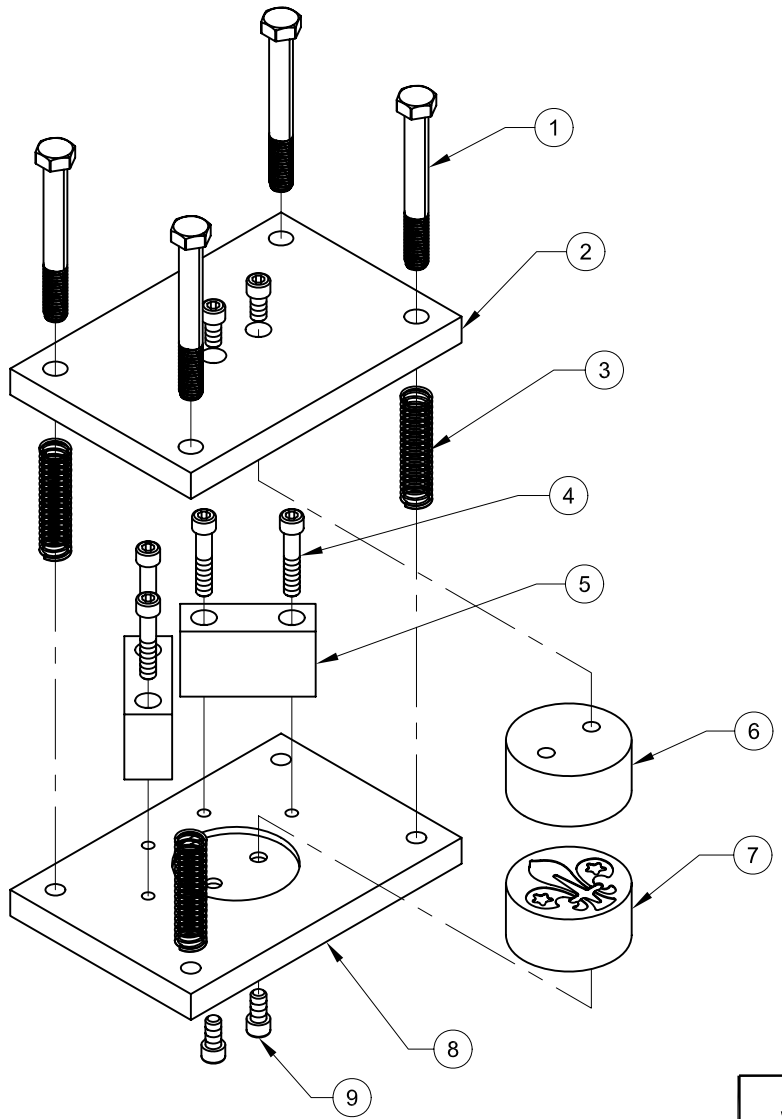

ISOMETRIC VIEW
(FOR REFERENCE ONLY)

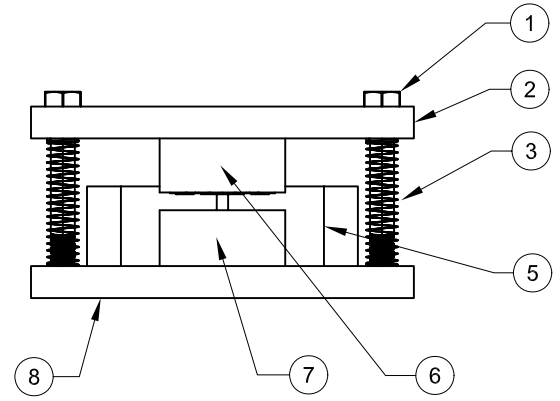
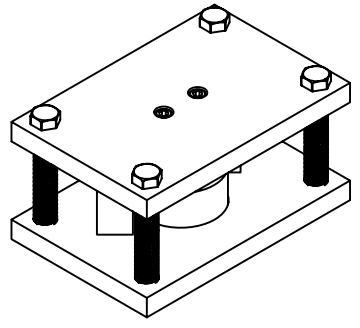

THIS DRAWING IS THE PROPERTY THE CUSTOMER. IT SHALL NOT BE COPIED (IN WHOLE OR IN PART), FOR MANUFACTURE OR OTHERWISE DISCLOSED WITHOUT PRIOR WRITTEN CONSENT OF THE CUSTOMER.		TOLERANCES		SCALE: 1:2	TITLE: PACK 409 PROJECT DIE SET, FLUER-DE-LIS	
		MACHINING	FABRICATION	DRAWN BY: MGATES	DATE: 01SEP09	SIZE: A
ESTIMATED WEIGHT:	FIRST ORDERED ON:	X. ±.040	ALL ANGULAR ±.06	CHECKED BY:	REV	
		X.X ±.020	ALL FINISHES 125μm	DATE:	DWG NO: ASSEMBLY	
		X.XX ±.010	DEBURR ALL SHARP CORNERS OR EDGES			
		X.XXX ±.005				
		ANGULAR ± 1/2°				

AUTOCAD DRAWING: FORM REVISION 09-01-00