

ITEM	QTY	DESCRIPTION	WIDTH	LENGTH	UM	PART NUMBER	MATERIAL	TYP
1	1	PLATE, 1/2" X 4"		6.0	EA		1080 CRS	CM

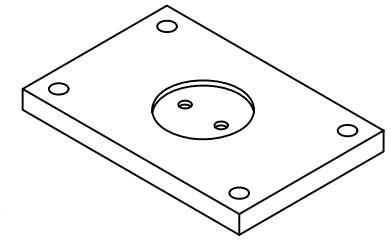
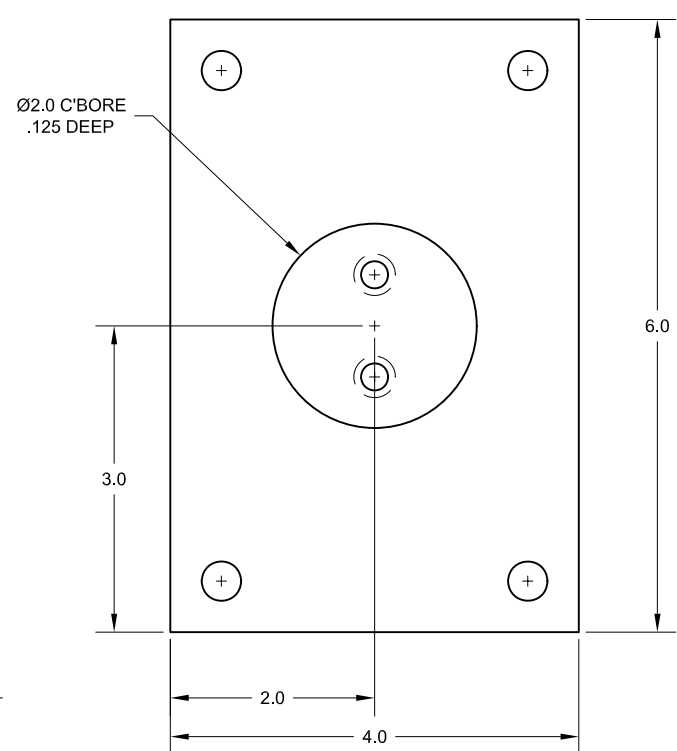
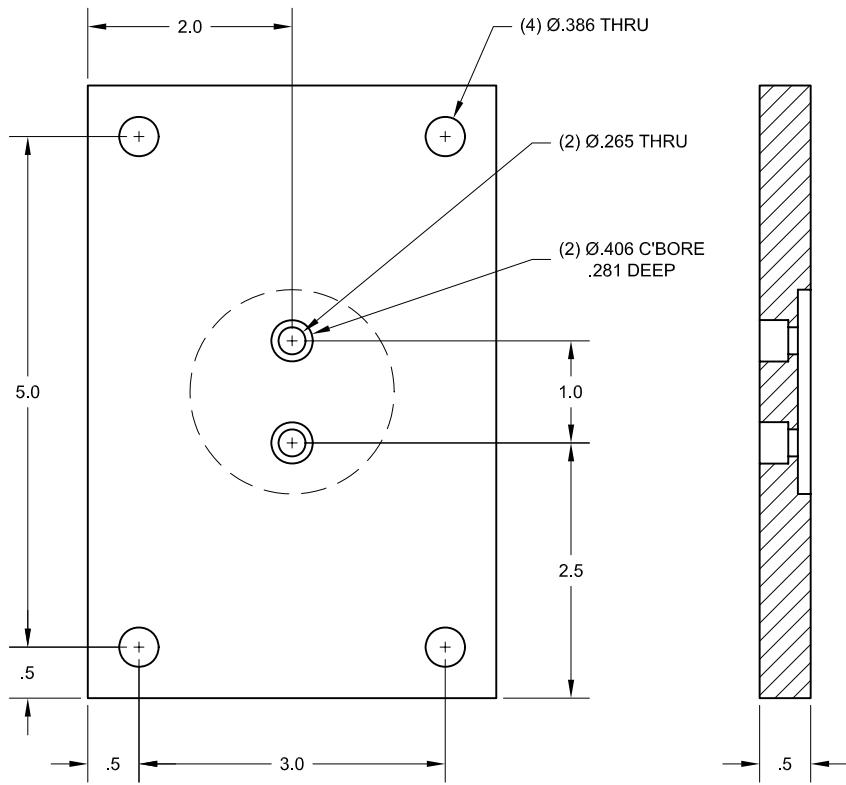

ISOMETRIC VIEW
(FOR REFERENCE ONLY)

THIS DRAWING IS THE PROPERTY THE CUSTOMER. IT SHALL NOT BE COPIED (IN WHOLE OR IN PART), FOR MANUFACTURE OR OTHERWISE DISCLOSED WITHOUT PRIOR WRITTEN CONSENT OF THE CUSTOMER.		TOLERANCES		SCALE: 1:1	TITLE: PACK 409 PROJECT DIE PRESS	
		MACHINING	FABRICATION	DRAWN BY: MGATES	DATE:	SIZE: A SHEET 1 OF 1 REV
ESTIMATED WEIGHT:	FIRST ORDERED ON:	X. ±.040	ALL ±.06	CHECKED BY:	DATE:	DWG NO: DIE PLATE, UPPER
		X,X ±.020	ANGULAR ±.2°			
		X,XX ±.010	ALL FINISHES 125µm			
		X,XXX ±.005	DEBURR ALL SHARP CORNERS OR EDGES			
		ANGULAR ± 1/2°				

AUTOCAD DRAWING: FORM REVISION 09-01-00

ITEM	QTY	DESCRIPTION	WIDTH	LENGTH	UM	PART NUMBER	MATERIAL	TYP
1	1	PLATE, 1/2" X 4"		6.0	EA		1080 CRS	CM

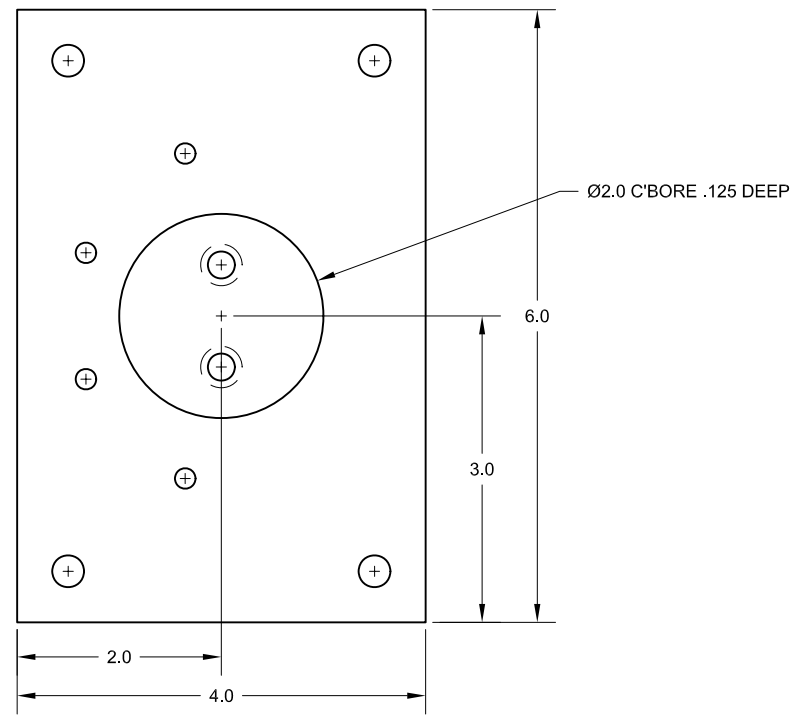
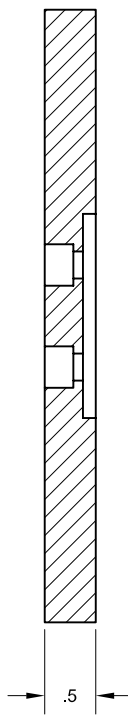
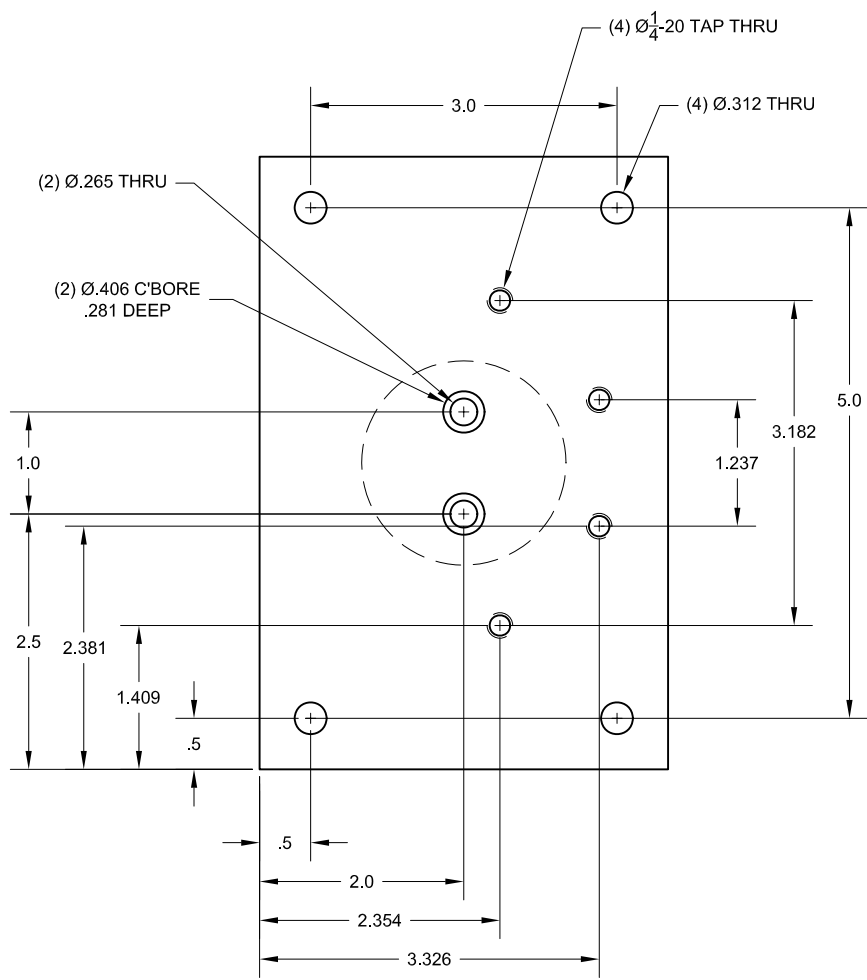
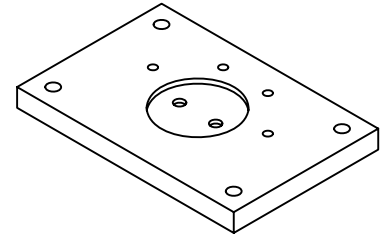

THIS DRAWING IS THE PROPERTY THE CUSTOMER. IT SHALL NOT BE COPIED (IN WHOLE OR IN PART), FOR MANUFACTURE OR OTHERWISE DISCLOSED WITHOUT PRIOR WRITTEN CONSENT OF THE CUSTOMER.		TOLERANCES		SCALE: 1:1	TITLE: PACK 409 PROJECT DIE PRESS
ESTIMATED WEIGHT:		FIRST ORDERED ON:	MACHINING	FABRICATION	DRAWN BY: MGATES
			X, ±.040	ALL ANGULAR ±.06	DATE:
			X,X ±.020	2"	CHECKED BY:
			X,XX ±.010	ALL FINISHES 125mu	DATE:
			X,XXX ±.005	DEBURR ALL SHARP CORNERS OR EDGES	SIZE: A SHEET 1 OF 1 REV
			ANGULAR ± 1/2"		DWG NO: DIE PLATE, LOWER

AUTOCAD DRAWING: FORM REVISION 09-01-00

ITEM	QTY	DESCRIPTION	WIDTH	LENGTH	UM	PART NUMBER	MATERIAL	TYP
1	1	BAR, RECT. 3/4" X 1-1/4"		2.125	EA		ALUM	CM

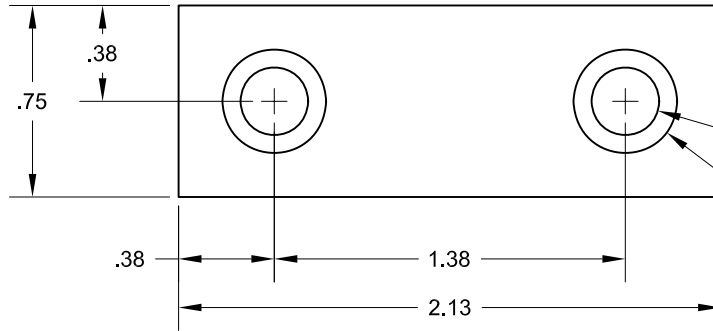

(2) Ø.265 THRU

(2) Ø.406 C'BORE .281 DEEP

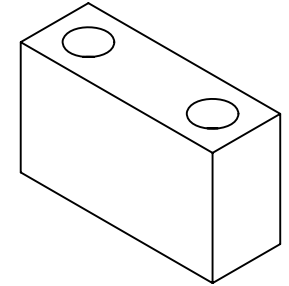

ISOMETRIC VIEW
(FOR REFERENCE ONLY)

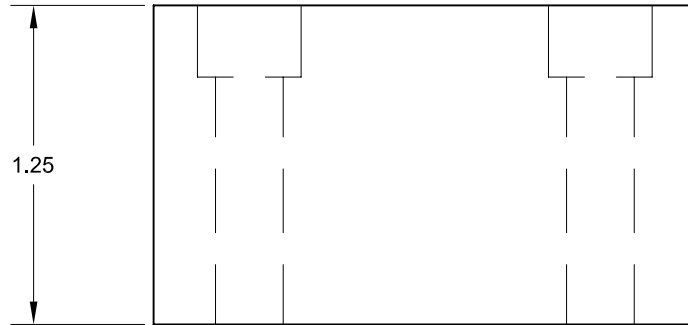

THIS DRAWING IS THE PROPERTY THE CUSTOMER. IT SHALL NOT BE COPIED (IN WHOLE OR IN PART), FOR MANUFACTURE OR OTHERWISE DISCLOSED WITHOUT PRIOR WRITTEN CONSENT OF THE CUSTOMER.		TOLERANCES		SCALE: 1:5	TITLE: PACK 409 PROJECT DIE SET	
		MACHINING	FABRICATION	DRAWN BY: MGATES	REV	
ESTIMATED WEIGHT:	FIRST ORDERED ON:	X, ±.040	ALL ANGULAR ±.06	DATE: 01SEP09	SIZE: A	SHEET 1 OF 1
		X,X ±.020	2"	CHECKED BY:	DWG NO :	
		X,XX ±.010	ALL FINISHES 125mm	DATE:	STOP	
		X,XXX ±.005	DEBURR ALL SHARP			
		ANGULAR ± 1/2"	CORNERS OR EDGES			