

ITEM	QTY	DESCRIPTION	WIDTH	LENGTH	UM	PART NUMBER	MATERIAL	TYP
1	1	BOLT, SHOULDER 3/8" X 1"		1	EA		STEEL	P
2	1	FRAME, FLIPBOOK			EA		ALUM	D
3	1	SETSCREW, 1/4"-20		.25	EA		STEEL	P
4	1	BAR, PICK HOLDER			EA		PLASTIC	P
5	1	PICK			EA		PLASTIC	P
6	1	CAPSCREW, BUTTON HEAD 10-32		.375	EA		STEEL	P
7	1	KNOB, TURNER			EA		ALUM	D
8	1	CAPCREW, IND HEX 1/4"-20		1.25	EA		STEEL	P
9	1	PACK, DRAWING (50 SHEETS)			EA		CARD STK	P
10	2	WASHER, 1/4"			EA		STEEL	P
11	2	CAPSCREW, BUTTON HEAD 1/4"-20		.750	EA		STEEL	P
12	1	BAR, SPINNER			EA		ALUM	D

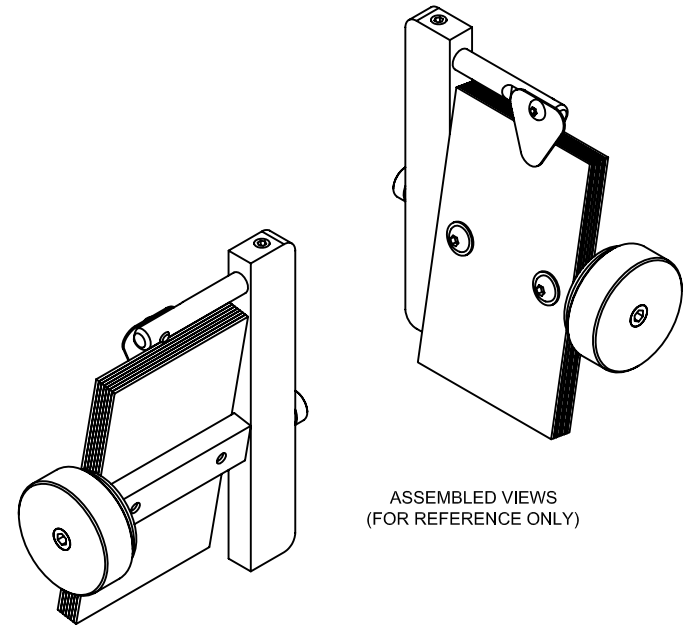

ASSEMBLED VIEWS
(FOR REFERENCE ONLY)

THIS DRAWING IS THE PROPERTY OF THE CUSTOMER. IT SHALL NOT BE COPIED (IN WHOLE OR IN PART), FOR MANUFACTURE OR OTHERWISE DISCLOSED WITHOUT PRIOR WRITTEN CONSENT OF THE CUSTOMER.		TOLERANCES		SCALE: 1:1	TITLE: PACK 409- PROJECT FLIPBOOK VIEWER
		MACHINING	FABRICATION	DRAWN BY: MGATES	DATE: 03NOV08
ESTIMATED WEIGHT:	FIRST ORDERED ON:	X. ±.040	ALL ±.06	CHECKED BY:	SIZE: A SHEET 1 OF 1
		X.X ±.020	ANGULAR 2°		DATE:
		X.XX ±.010	ALL FINISHES 125mu		DWG NO: ASSEMBLY
		X.XXX ±.005	DEBURR ALL SHARP CORNERS OR EDGES		
		ANGULAR ± 1/2°			

AUTOCAD DRAWING: FORM REVISION 09-01-00