

ITEM	QTY	DESCRIPTION	WIDTH	LENGTH	UM	PART NUMBER	MATERIAL	TYP
1	1	BAR, RECT. 1/2" X 3/4"		13.75	EA		OAK	CM
2	1	BAR, RECT. 7/8" X 1-1/4"		2.50	EA		ALUM	CM
3	1	BAR, RECT. 1/2" X 3/4"		3.00	EA		ALUM	CM

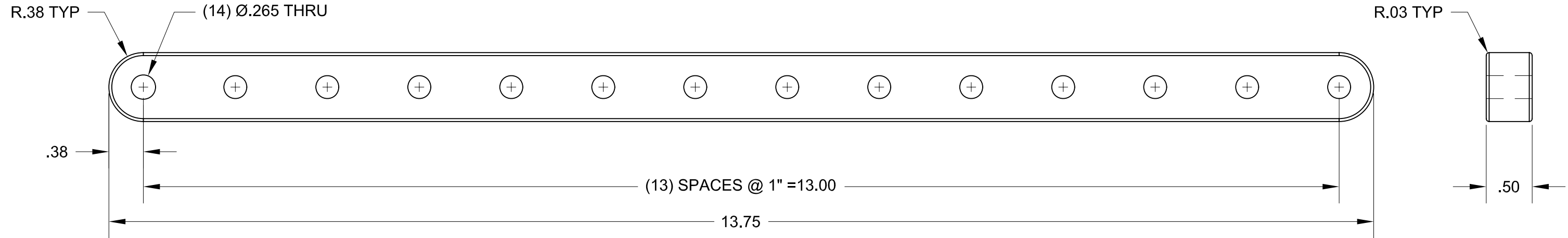

ITEM 1
SCALE 1:1

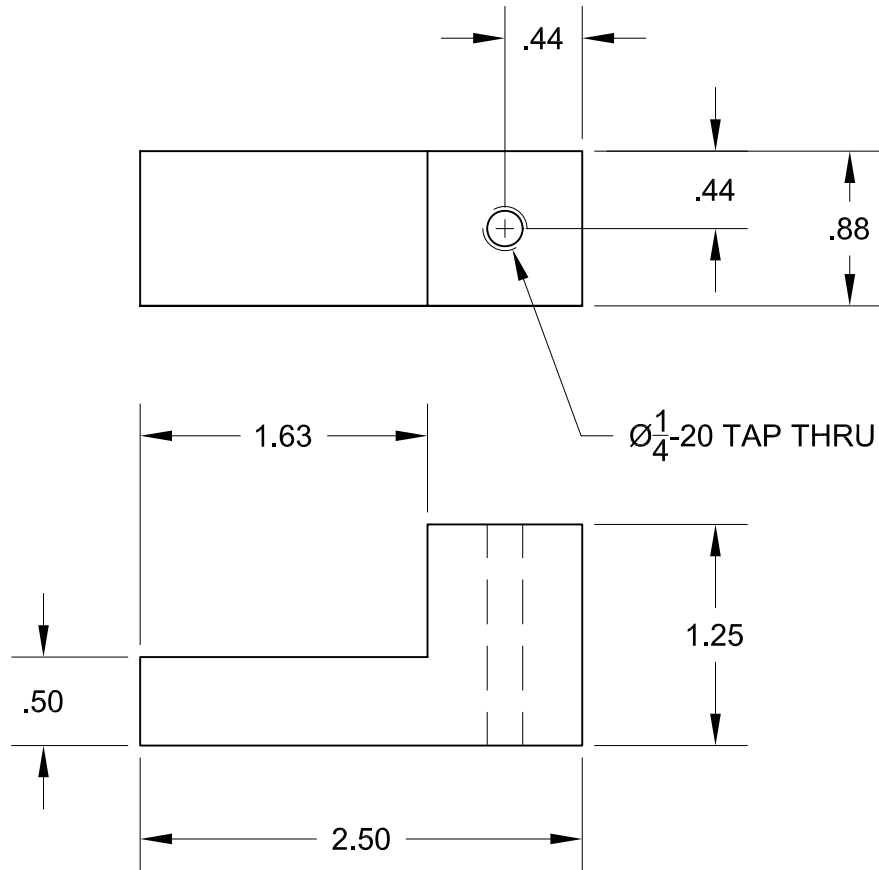

ITEM 2
SCALE 1:1

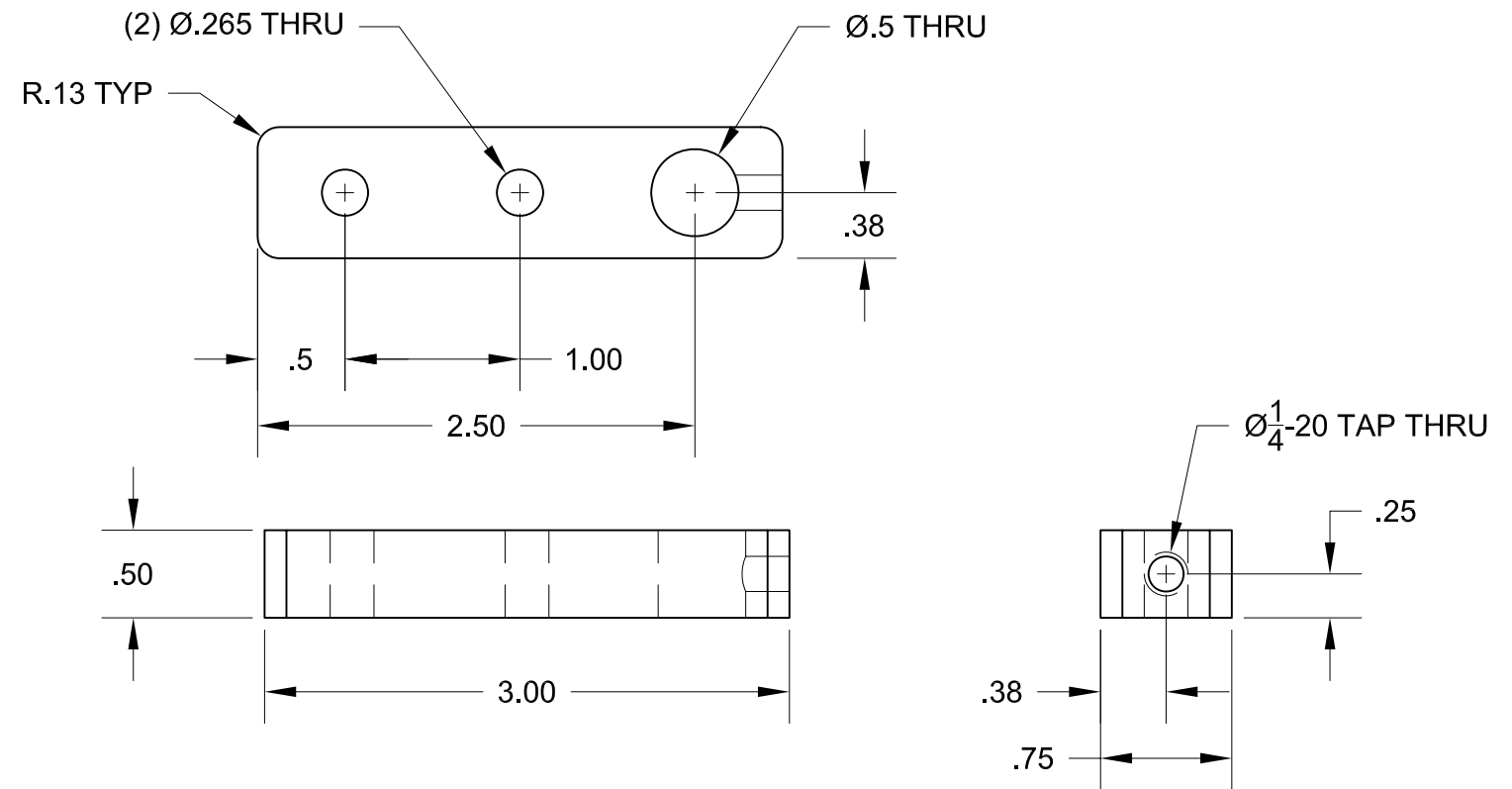

ITEM 3
SCALE 1:1

A ALMOST ANY MATERIAL CAN BE SUBSTITUTED FOR THE LISTED ITEMS.
WOOD, ALUMINUM, STEEL, PLASTIC

THIS DRAWING IS THE PROPERTY OF THE CUSTOMER. IT SHALL NOT BE COPIED (IN WHOLE OR IN PART), FOR MANUFACTURE OR OTHERWISE DISCLOSED WITHOUT PRIOR WRITTEN CONSENT OF THE CUSTOMER.	TOLERANCES		SCALE: 1:1	TITLE: PACK 409- PROJECT PANTING PANTAGRAPH	
	MACHINING	FABRICATION	DRAWN BY: MGATES	DATE:	SIZE: A SHEET 1 OF 1
ESTIMATED WEIGHT:	FIRST ORDERED ON:	X. ±.040 X.X ±.020 X.XX ±.010 X.XXX ±.005 ANGULAR ± 1/2°	ALL ANGULAR ±.06 2° ALL FINISHES 125mu DEBURR ALL SHARP CORNERS OR EDGES	CHECKED BY:	REV
			DATE:	DWG NO: COMPONENTS	

AUTOCAD DRAWING: FORM REVISION 09-01-00