

ITEM	QTY	DESCRIPTION	WIDTH	LENGTH	UM	PART NUMBER	MATERIAL	TYP
1	1	SHEET, PLASTIC .03 THICK (BLUE)	2	2	EA		VINYL	CM
2	1	SHEET, PLASTIC .03 THICK (BLACK)	2.25	2.25	EA		VINYL	P
2	1	LEATHER, TOOLING 1/8" THICK	.750	4.500	EA		LEATHER	P

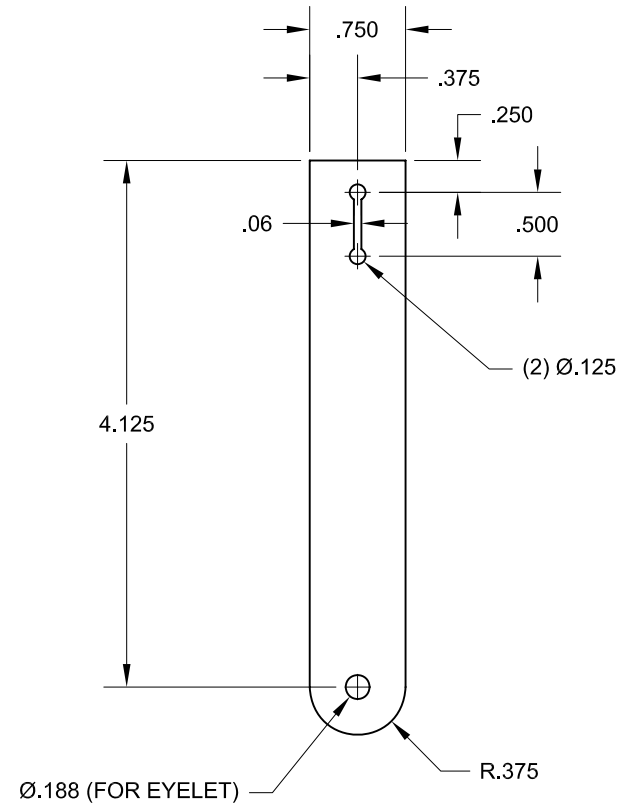
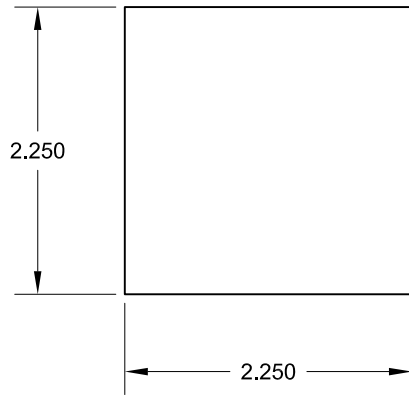
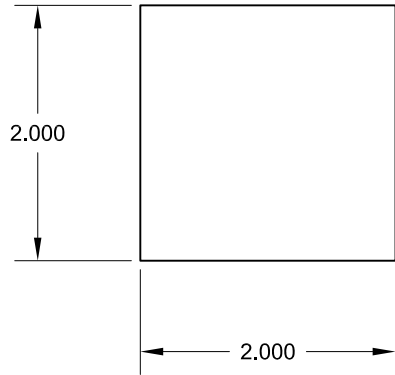

A A GOOD SOURCE FOR THE VINYL MATERIAL IS RECYCLED VINYL NOTEBOOK BINDERS. THEY COME IN A VARIETY OF COLORS AND CAN BE CUT EASILY ON A PAPER CUTTER.

THIS DRAWING IS THE PROPERTY THE CUSTOMER. IT SHALL NOT BE COPIED (IN WHOLE OR IN PART), FOR MANUFACTURE OR OTHERWISE DISCLOSED WITHOUT PRIOR WRITTEN CONSENT OF THE CUSTOMER.		TOLERANCES		SCALE: 1:1	TITLE: PACK 409- PROJECT
		MACHINING	FABRICATION	DRAWN BY: MGATES	PROGRESS TOWARDS RANKS
		X ±.040	ALL ANGULAR ±.06	DATE: 22SEPT08	SIZE: A SHEET 1 OF 1 REV
		X.X ±.020	ALL FINISHES 125mu	CHECKED BY:	DWG NO: COMPONENTS
		X.XX ±.010	DEBURR ALL SHARP CORNERS OR EDGES	DATE:	
ESTIMATED WEIGHT:	FIRST ORDERED ON:	X.XXX ±.005			
		ANGULAR ± 1/2°			