

ITEM	QTY	DESCRIPTION	WIDTH	LENGTH	UM	PART NUMBER	MATERIAL	TYP
1	1	PLATE, CRANK			EA		PLYWOOD	D
2	1	ROD, SPEAKER HOLDER			EA		WIRE	D
3	1	BASE, SPOOL			EA		WOOD	D
4	2	SPACER, SPOOL			EA		WOOD	D
5	1	HANDLE			EA		DOWEL	D
6	1	HANDLE, CRANK			EA		DOWEL	D
7	1	HANDLE, SPEAKER			EA		DOWEL	D
8	1	SPOOL			EA		PLASTIC	D
9	1	PIVOT, SPOOL			EA		DOWEL	D

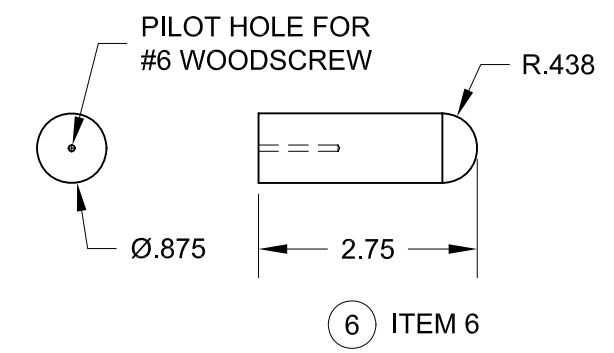

A THESE SPOOLS ARE USED ON WIRE E.D.M. MACHINES AND ARE TYPICALLY THROWN AWAY OR RECYCLED. THEY ARE PLASTIC AND COME IN SEVERAL COLORS. THE SPOOLS WE USED ARE REFERRED TO AS DIN-160 SPOOLS. CONTACT YOUR LOCAL MACHINE SHOP THAT USES A WIRE E.D.M.'S AND ASK THEM WHAT THEY DO WITH THERE USED (EMPTY) SPOOLS.

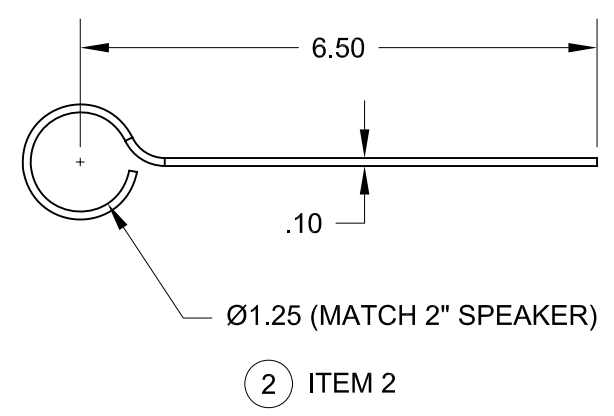
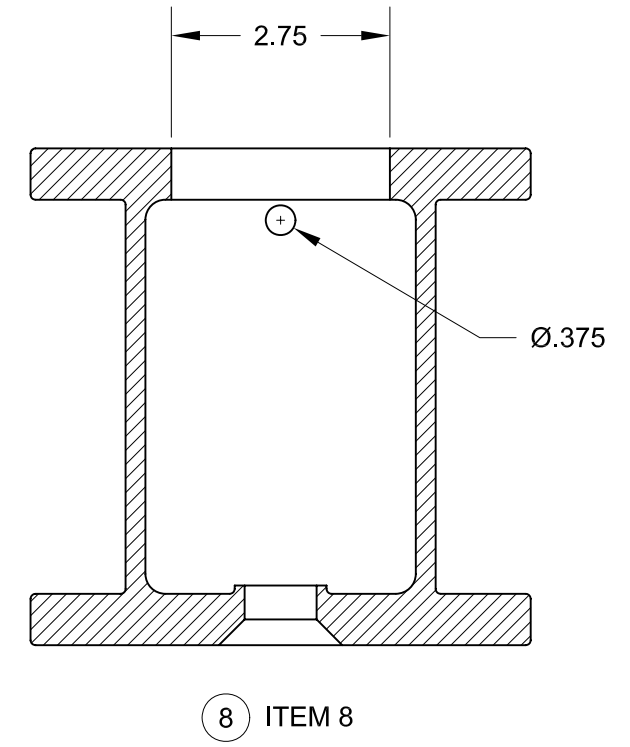
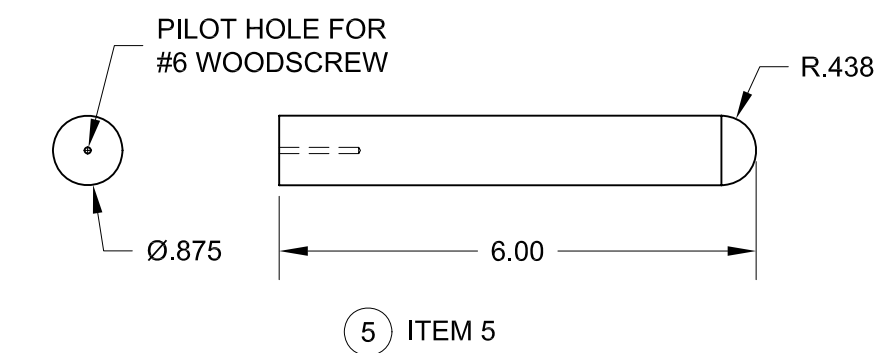
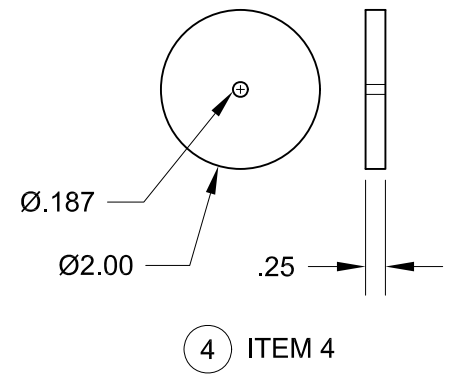
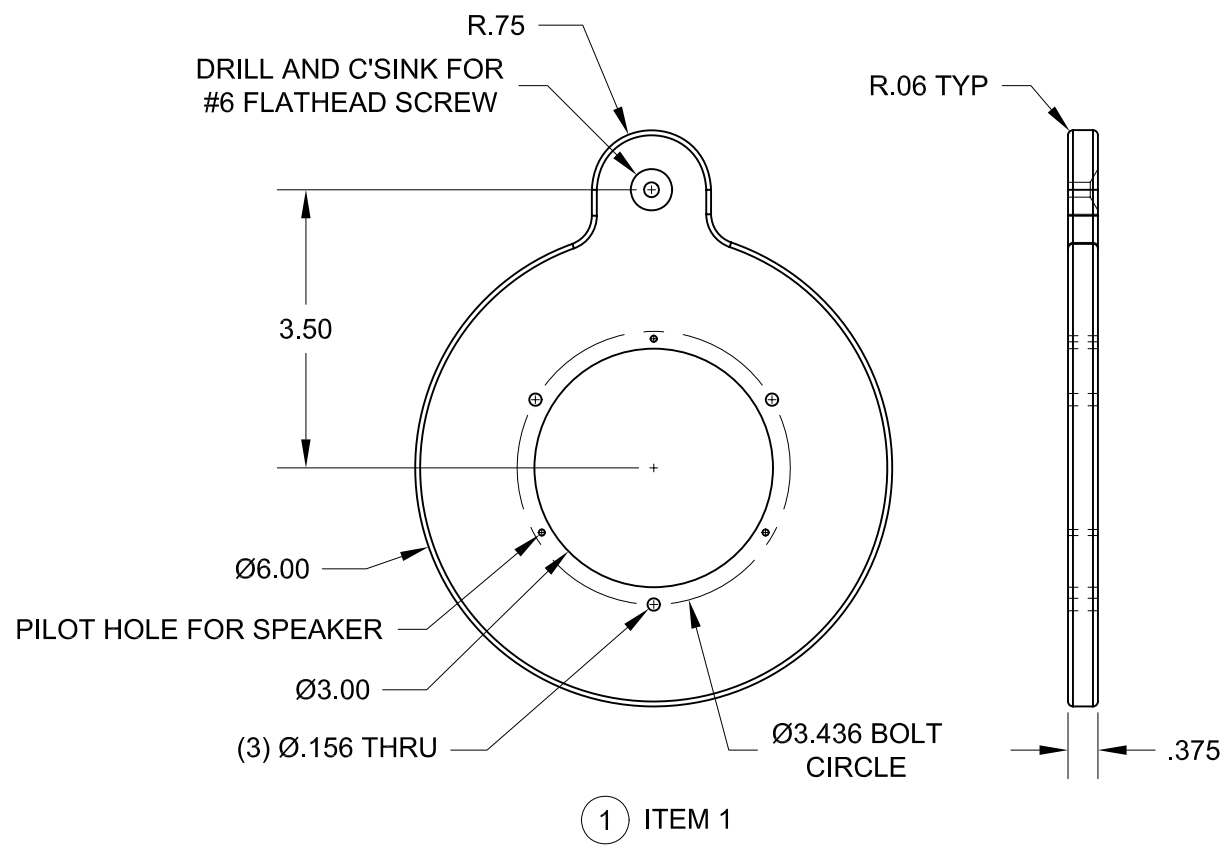
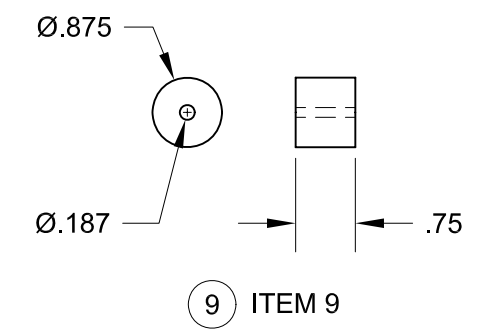
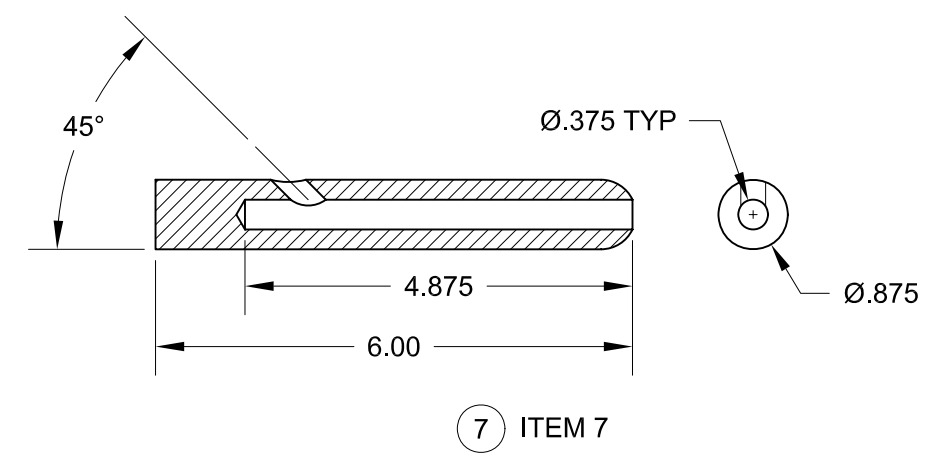
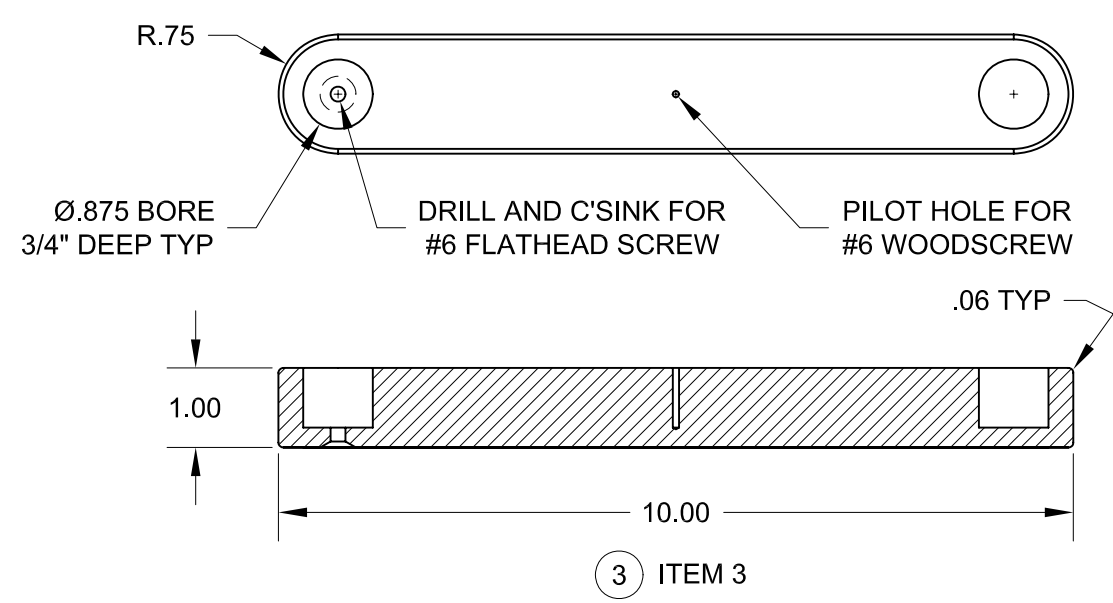

THIS DRAWING IS THE PROPERTY THE CUSTOMER. IT SHALL NOT BE COPIED (IN WHOLE OR IN PART), FOR MANUFACTURE OR OTHERWISE DISCLOSED WITHOUT PRIOR WRITTEN CONSENT OF THE CUSTOMER.		TOLERANCES		SCALE: 1:2	TITLE: PACK 409- PROJECT ROGER WILCO	
		MACHINING	FABRICATION	DRAWN BY: M GATES		
ESTIMATED WEIGHT:	FIRST ORDERED ON:	X.	± .040	ALL	± .06	DATE:
		X.X	± .020	ANGULAR	2°	
		X.XX	± .010	ALL FINISHES	125mu	CHECKED BY:
		X.XXX	± .005	DEBURR ALL SHARP		DATE: 16NOV09
		ANGULAR	± 1/2°	CORNERS OR EDGES		DWG NO: COMPONENTS
				SIZE: A	SHEET 1 OF 1	REV

AUTOCAD DRAWING - FORM REVISION 00 01 00