

ITEM	QTY	DESCRIPTION	WIDTH	LENGTH	UM	PART NUMBER	MATERIAL	TYP
1	1	SAIL			EA		PLASTIC	D
2	1	MAST			EA		WOOD	D
3	1	NAIL, BRAD ROUND HEAD		.75	EA		STEEL	P
4	1	HULL			EA		WOOD	D
5	1	KEEL/RUDDER			EA		ALUM	D
6	2	SCREW, ROUND HEAD #6		.500	EA		STEEL	P
7	1	WIRE, SAIL ADJUSTMENT (CRAFT)		6.00	EA		STEEL	D

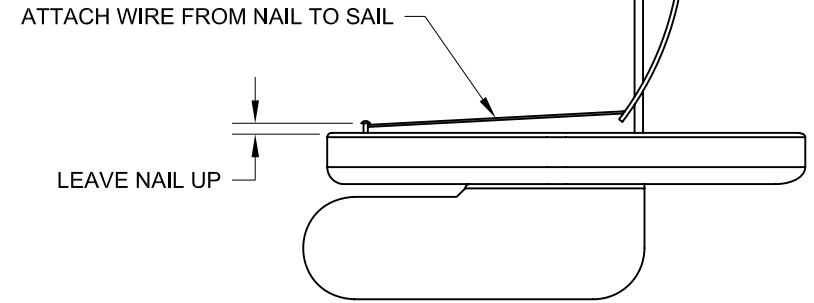
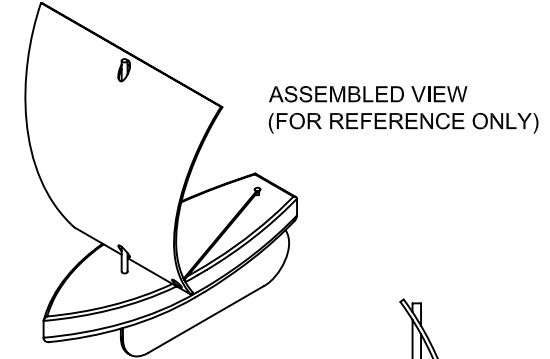

THIS DRAWING IS THE PROPERTY THE CUSTOMER. IT SHALL NOT BE COPIED IN WHOLE OR IN PART, FOR MANUFACTURE OR OTHERWISE DISCLOSED WITHOUT PRIOR WRITTEN CONSENT OF THE CUSTOMER.		TOLERANCES		SCALE: 1:1	TITLE: PACK 409 PROJECT SAILBOAT
		MACHINING	FABRICATION	DRAWN BY:	DATE:
		X. ±.040 X.X ±.020 X.XX ±.010 X.XXX ±.005 ANGULAR ± 1/2"	ALL ANGULAR ±.06" ALL FINISHES 125µm DEBURR ALL SHARP CORNERS OR EDGES	CHECKED BY:	DATE:
ESTIMATED WEIGHT:	FIRST ORDERED ON:			SIZE: A	SHEET 1 OF 1
				ASSEMBLY	

AUTOCAD DRAWING: FORM REVISION 09-01-00